

DESIGNED FOR CRITICAL APPLICATIONS



Unit shown with optional Silicone Door Gasket – Neoprene is standard.

BAG-IN/BAG-OUT HOUSINGS FOR HEPA FILTERS AND OPTIONAL PREFILTERS



FEATURES:

- ☑ For Containment of Bio-Hazards
- ☑ Utilize Bag-In/Bag-Out System to Change Filters
- ☑ Available in Either Gasket Seal or Gel Seal
- ☑ Factory Assembled
- ☑ Available in 304, 304L, 316 Stainless Steel or Aluminized Steel
- ☑ Heavy Duty Construction
- ☑ Optional Prefilter Section
- ☑ Seal Welded Construction
- ☑ Tested Up To 10" W.G.
- ☑ Large List of Options

The TRI-LOCK BG/BF™ HEPA Bag-In/Bag-Out air filter housings are designed for critical applications, applications that require containment of potentially hazardous materials or applications where protection of maintenance personnel changing the air filters is needed.

The TRI-LOCK BG/BF™ housings utilize the Bag-In/Bag-Out system of changing filters that isolates personnel and the ambient surroundings from exposure by use of a PVC bag enclosure system.

The TRI-LOCK BG/BF™ housings are available to house either gasket or gel seal HEPA filters. The TRI-LOCK BG/BF™ housings feature a heavy-duty design that is essential for the demanding and critical clean air applications that require HEPA filtration.

The TRI-LOCK BG/BF™ is a factory-assembled unit of one-piece construction. Each TRI-LOCK BG/BF™ housing is manufactured to meet end-user requirements.

The TRI-LOCK BG/BF™ housings are constructed of 304 Stainless Steel as their standard construction with optional 304L Stainless Steel, 316 Stainless Steel or Aluminized Steel. All seams are seal welded to insure leak free construction. An optional prefilter section is available to accommodate 2", 4" or 6" deep prefilters.

Tri-Dim's TRI-LOCK housing offers a true HEPA locking mechanism that will properly seal the HEPA filter in the housing thus reducing the potential for air bypass in your critical environments.

The TRI-LOCK BG/BF™ housing offers hand torqued door latches to provide a positive pressure door-to-housing seal as well as ease of filter servicing.

The TRI-LOCK BG/BF™ housings come with a factory-installed flange that is suitable for connection to either ductwork or to the air handler system. The TRI-LOCK BG/BF™ housings are also available to hold carbon adsorbers for the removal of hazardous molecular contamination. All TRI-LOCK BG/BF™ housings are tested in accordance with ANSI/ANSE-N510-1995 for pressure decay up to ± 10 " W.G. to assure you a leak free housing.

The Bag-In/Bag-Out Changing system completely contains the hazardous air stream and contaminated filter in an 8-Mil poly vinyl chloride bag that is attached to the ribbed access port. The standard PVC bag contains three glove sections so contaminated filters can be easily and safely removed and bagged.

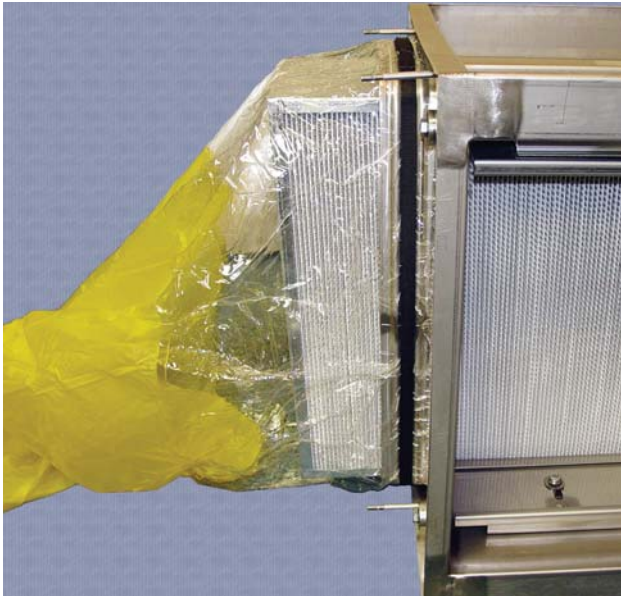

Tri-Lock Bag-In/Bag-Out housing with PVC bag in place



Tri-Lock Bag-In/Bag-Out housing showing close-up of door latch and gasket seal locking mechanism

TRI-PURE™ HEPA & HEPAMAX™

Tri-Dim offers a full line of separator style HEPA filters to meet your application demands. Tri-Dim offers both standard capacity HEPA filters, which are rated at 250 FPM, and high capacity HEPAMAX™ filters rated at 500 FPM. Tri-Dim offers both versions in gasket or gel seal, particleboard or metal frame construction, and high temperature models to correspond with your requirements. Varying levels of efficiency and testing methods are available starting at 99.97% @ 0.3 microns. Please contact your local sales representative or local office for more information on Tri-Dim's TRI-PURE™ HEPA and HEPAMAX™ filters.

APPLICATIONS

TRI-LOCK™ HEPA Bag-In/Bag-Out housing are designed for use in environments that contain hazardous materials. Some specific applications include:

- **Pharmaceutical**
- **Food Processing Industry**
- **Industrial Process Exhaust**
- **Genetic Research**
- **Hospital Isolation Areas**
- **Microelectronics**
- **Radioisotope Handling**
- **Research Laboratories**
- **Veterinary Research**
- **Government Facilities**

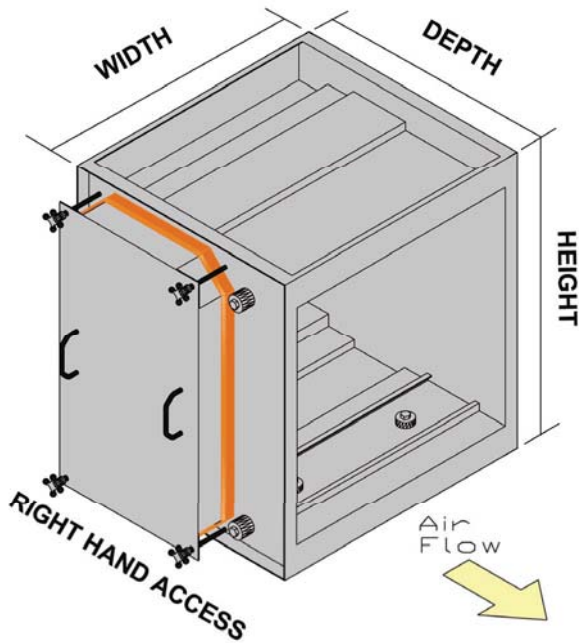

TRI-LOCK BG/BF™ Options

- ▲ Drain
- ▲ Drilled Flanges
- ▲ Lifting Lugs
- ▲ Silicone Door Gasket
- ▲ Photohelic Gauge
- ▲ Magnehelic Gauge
- ▲ DOP Ports
- ▲ Bolt Sections in Series
- ▲ Prefilter Section Only
- ▲ Double Wall Insulation
- ▲ Filter Support Shelf
- ▲ High Temperature Door Gasket
- ▲ NEMA 4 Cover
- ▲ Welded Sections in Series
- ▲ Adsorber Section (16 or 18")
- ▲ Bag Kit
- ▲ Nameplate
- ▲ Static Taps
- ▲ Transitions
- ▲ Special Sizes

TRI-LOCK BG/BF™ Specifications and Drawing

LEGEND Capacity Dimensions (HxW) Number of Filters Face Area (Sq. Ft.)		Unit Width		
		1	2	3
Unit Height	1	2,000 CFM 29-3/4" x 27" 1-24x24 Filter 4 Sq Ft	4,000 CFM 29-3/4" x 51" 2-24x24 Filter 8 Sq Ft	6,000 CFM 29-3/4" x 75" 3-24x24 Filter 12 Sq Ft
	2	4,000 CFM 59-1/2" x 27" 2-24x24 Filter 8 Sq Ft	8,000 CFM 59-1/2" x 51" 4-24x24 Filter 16 Sq Ft	12,000 CFM 59-1/2" x 75" 6-24x24 Filter 24 Sq Ft
	3	6,000 CFM 89-1/4" x 27" 3-24x24 Filter 12 Sq Ft	12,000 CFM 89-1/4" x 51" 6-24x24 Filter 24 Sq Ft	18,000 CFM 89-1/4" x 75" 9-24x24 Filter 36 Sq Ft

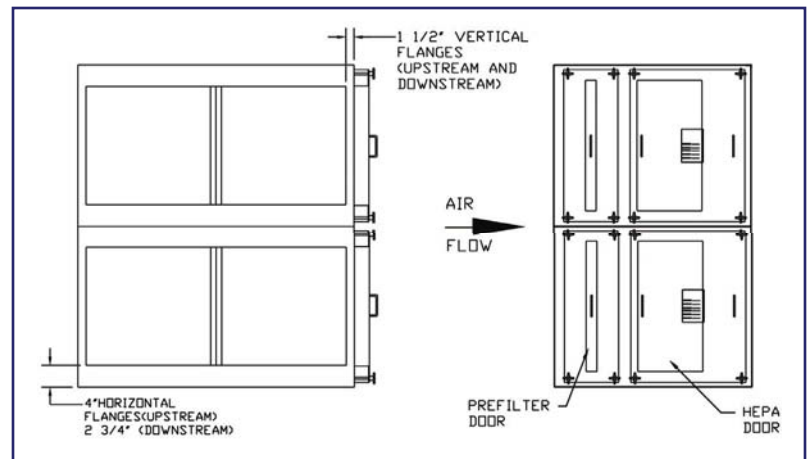

NOTES

- Capacity** is reported in CFM at a flow rate of 500 FPM
- Dimensions** are reported in exact size in inches and Height x Width
- Number of Filters** are reported in quantity and exact dimensions
- Face Area** is reported as face area of air filters – exact size in square feet
- Standard Housing Depths** relative to depth of prefilters
 No Prefilter = 24"
 2" Thick Prefilter = 36-1/2"
 4" Thick Prefilter = 36-1/2"
 6" Thick Prefilter = 36-1/2"
 Custom depths available
- Special and Half Size Units** are available

Tri-Dim Filter Corporation is committed to continual product development – all descriptions and specifications are subject to change without notice.

Tri-Dim® and Tri-Dek® are Registered Trademarks of Tri-Dim Filter Corporation. Tri-Lock™, Tri-Pure™ and HEPAMAX™ are Trademarks of Tri-Dim Filter Corporation.



TRI-DIM FILTER CORPORATION

P.O. BOX 466 • 93 INDUSTRIAL DRIVE
LOUISA, VA 23093

(540) 967-2600 • FAX: (540) 967 2835

EMAIL: info@tridim.com • Website: www.tridim.com

TOLL FREE 1-800-458-9835

Local Representation: