

**MULTIPLE STAGE
SIDE ACCESS
HOUSING FOR
ASHRAE RATED
FILTERS**

FEATURES:

- ☑ Available in Three Stock Depths
- ☑ Available in Galvanized and Stainless Steel
- ☑ Welded Construction
- ☑ Corner Supports for Rigidity
- ☑ Flexible in Possible Filter Options
- ☑ Perform up to ± 3 " W.G.
- ☑ Positive Tension, Gasketed Doors
- ☑ Factory Installed Flange
- ☑ Large List of Options

The TRI-MET SA™ Side Access air filter housing is a permanent housing designed to specifically accommodate two stages of ASHRAE rated prefilters and final filters.

The TRI-MET SA™ Side Access housing is available in three standard depths, of 22- $\frac{1}{4}$ ", 34- $\frac{1}{4}$ ", 42", or a customized depth. The housing is manufactured with galvanized steel or optional stainless steel and is intermittently welded together for strength. All seams are silicone caulked for airtight seal. Upstream corner supports increase the rigidity of the unit.

The TRI-MET SA™ Side Access unit utilizes one-piece construction with a filter track extrusion permitting either a 2", 4" or 6" prefilter track and a 1" final filter header track. Each housing is custom manufactured to meet specific end user requirements.

The TRI-MET SA™ Side Access housing accommodates different types and efficiencies of air filters. Check individual filter rating to determine specific efficiency and flow rates. The recommended system static pressure range for the housing is ± 3 " W.G.

Positive tension door locks make filter servicing easy and combined with a perimeter gasketing around the door ensures a positive seal. Factory installed flange is suitable for connection to either ductwork or air handling system.

The TRI-MET SA™ comes with a large number of options so housings can be customized to meet any application specific requirements.

TRI-MET SA™ Options

- ▲ Vertical Flow Application
- ▲ Weather Cover
- ▲ Bottom Access
- ▲ Lifting Lugs
- ▲ Transitions
- ▲ Custom and Drilled Flanges
- ▲ Double Wall Insulation
- ▲ Static Port(s)
- ▲ Magnehelic Gauge
- ▲ Photohelic Gauge
- ▲ High Temperature Gasket

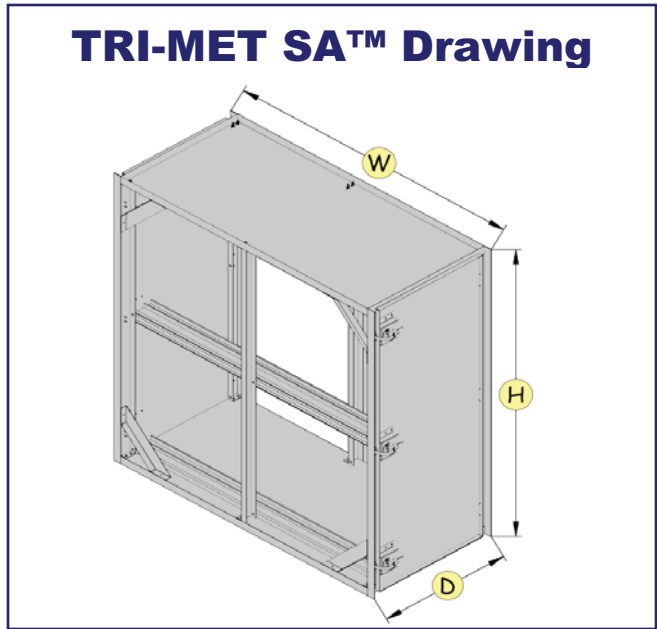

TRI-MET SA™ Specifications

LEGEND		Unit Width			
Capacity					
Dimensions (HxW)					
Number of Filters					
Face Area (Sq. Ft.)					
		1	2	3	4
Unit Height	1	2,000 CFM 26-7/8"x26-1/8" 1-24x24 Filter 4 Sq Ft	4,000 CFM 26-7/8"x49-1/2" 2-24x24 Filter 8 Sq Ft	6,000 CFM 26-7/8"x72-7/8" 3-24x24 Filter 12 Sq Ft	8,000 CFM 26-7/8"x96-1/4" 4-24x24 Filter 16 Sq Ft
	2	4,000 CFM 51"x26-1/8" 2-24x24 Filter 8 Sq Ft	8,000 CFM 51"x49-1/2" 4-24x24 Filter 16 Sq Ft	12,000 CFM 51"x72-7/8" 6-24x24 Filter 24 Sq Ft	16,000 CFM 51"x96-1/4" 8-24x24 Filter 32 Sq Ft
	3	6,000 CFM 75-1/8"x26-1/8" 3-24x24 Filter 12 Sq Ft	12,000 CFM 75-1/8"x49-1/2" 6-24x24 Filter 24 Sq Ft	18,000 CFM 75-1/8"x72-7/8" 9-24x24 Filter 36 Sq Ft	24,000 CFM 75-1/8"x96-1/4" 12-24x24 Filter 48 Sq Ft
	4	8,000 CFM 99-1/4"x26-1/8" 4-24x24 Filter 16 Sq Ft	16,000 CFM 99-1/4"x49-1/2" 8-24x24 Filter 32 Sq Ft	24,000 CFM 99-1/4"x72-7/8" 12-24x24 Filter 48 Sq Ft	32,000 CFM 99-1/4"x96-1/4" 16-24x24 Filter 64 Sq Ft

NOTES

Capacity is reported in CFM at a flow rate of 500 FPM

Dimensions are reported in exact size in inches and Height x Width

Number of Filters are reported in quantity and nominal dimensions

Face Area is reported as face area of air filters – nominal size in square feet

Standard Housing Depths relative to depth of final filters
 12-15" = 22-1/4"
 15-26" = 34-1/4"
 26-36" = 42"
 Custom depths available

Special and Half Size Units are available

Tri-Dim Filter Corporation is committed to continual product development – all descriptions, specifications and performance data are subject to change without notice.

Tri-Dim® and Tri-Dek® are Registered Trademarks of Tri-Dim Filter Corporation. Tri-Met™ is a Trademark of Tri-Dim Filter Corporation.



TRI-DIM FILTER CORPORATION
 P.O. BOX 466 • 93 INDUSTRIAL DRIVE
 LOUISA, VA 23093

(540) 967-2600 • FAX: (540) 967-2835

EMAIL: info@tridim.com • Website: www.tridim.com
 TOLL FREE 1-800-458-9835

Local Representation: